

cisal

CHÉRIE
Collection

design by Cisol Atelier



cisal



cisal

PATTARDI

«La bellezza del luogo ci illude, e a momenti ci fa credere che il tempo si sia fermato»

Orta mia. Mario Soldati 1960

“The beauty of this place deceives us, and at times makes us believe that time stands still”

Orta mia. Mario Soldati 1960



CHI SIAMO

CISAL rappresenta un esempio di industria italiana autonoma ed integrata, a ciclo di produzione completo, caratterizzato da soluzioni tecnologiche e gestionali innovative. Cisal è oggi uno dei protagonisti dell'innovazione nel settore, con grande sensibilità per l'efficiente uso delle risorse, in primis acqua ed energia, e costante attenzione allo sviluppo continuo di prodotti innovativi nel design, nei materiali, nel funzionamento e nelle prestazioni. Le Collezioni, combinano sapientemente estetica, funzionalità e affidabilità, grazie alla collaborazione con designers internazionali quali Karim Rashid, Giampiero Peia, Raffaella Vecchi, Nevio Tellatin, Marco Poletti.



1952

Fondata nel 1952 da Liborio Soldi e battezzata CISAL, la società ha attraversato tutte le stagioni dell'epopea della rubinetteria di cui il Cusio è protagonista fin dagli albori.

Founded in 1952 by Liborio Soldi and named CISAL, the company has gone through all the epic seasons of brassware industry where Cusio has been the protagonist since the beginning.



1980

Nel 1980 l'Arch. Raffaella Vecchi disegna la serie ARCANA, un prodotto icona classico e storico che apre nuovi orizzonti nei mercati esteri, che si sviluppano passando anche attraverso la creazione di una filiale in Germania nel 1991.

In 1980 the Architect Raffaella Vecchi, designed the ARCANA series, a classical and historical icon that opens up new horizons in foreign markets, which also led to the establishment of a daughter company in Germany in 1991.



1981

Dal lavoro di sviluppo interno coordinato da Daniele Sirini, nasce la prima cartuccia a dischi ceramici monocomando. Il nuovo BLITZ apre la gloriosa storia delle serie di miscelazione Cisal.

The first single handle ceramic disc cartridge was developed internally by Daniele Sirini and his team. The glorious history of Cisal mixer series begins with the new BLITZ series.

ABOUT US

Cisal is the outstanding example of an independent and fully integrated Italian manufacturer, performing the complete production cycle, characterised by innovative technology and management solutions.

Cisal is now one of the leading innovators in the industry and is very conscience about the efficient use of resources, water and energy, and focuses on the continuous development of innovative products with regard to design, materials, function and performance. Thanks to collaboration with international designers such as Karim Rashid, Giampiero Peia, Raffaella Vecchi, Nevio Tellatin and Marco Poletti, the Collections masterfully combine aesthetics, functionality and reliability.



1999

Nel 1999, viene realizzato un nuovo stabilimento disegnato dall'Arch. Giampiero Peia e attrezzato con modernissimi impianti di cogenerazione, galvanica e magazzino elettronico. Qui si concentrano le tecnologie più avanzate del settore e si supporta una crescita continua nella progettazione del prodotto, nell'ingegnerizzazione del manufatto e del prodotto finito.

In 1999, a new factory building designed by the architect Giampiero Peia was built and equipped with modern cogeneration and plating plants along with an electronic warehouse. Here, using the most advanced technologies in the industry, product design and the engineering of the part and the finished product are in continuous development.



2009

Nel 2009 la famiglia Huber, proprietaria di Huber, leader nella fabbricazione di miscelatori termostatici, decide di fare una scelta strategica per il futuro, acquisendo Cisal per garantirle un asse di sviluppo tecnologico e industriale assolutamente vincente: combinare know-how, esperienza e capacità produttive per offrire al progettista e alla clientela una variegata e completa gamma di prodotti integrati a miscelazione termostatica, monocomando e tradizionale.

In 2009 the Huber family, owner of Huber, a leading manufacturer of thermostatic mixers, decided to make a strategic choice for the future, by acquiring Cisal and providing the company with an absolutely successful technological and industrial development format: to combine know-how, experience and production capacities in order to offer designers and customers a wide and complete range of single lever, traditional, and thermostatic brassware products.



2016

Nel 2016 l'Architetto Fabio Rotella entra a far parte del team dell'azienda e in qualità di art director ha ideato "CISALAtelier", centro creativo che, attraverso la ricerca e la sperimentazione, lavorerà su progetti di prodotti sempre più protagonisti, grazie ad un autentico appeal.

Architect Fabio Rotella joining the team in 2016: as the brand art director, he developed the "CISALAtelier" concept, a creative network which, through research and experimentation, will be protagonist on projects of key products thanks to their authentic appeal.



ECCELLENZA MADE IN ITALY

Cisal, rappresenta un capitolo importante della storia della rubinetteria italiana. Una lunga tradizione di ingegno, mestiere e professionalità, declinata ed esaltata nel rispetto e nella considerazione per l'uomo ed il territorio: il Lago d'Orta, luogo in cui si concentra da generazioni il distretto della rubinetteria, retaggio di artigianalità e cultura del saper fare italiano.

MADE IN ITALY EXCELLENCE

Cisal represents an important chapter in the history of Italian brassware. A long tradition of ingenuity, skill and professionalism, identified and enhanced in respect and consideration for humans and the territory: Lake Orta, the area where taps have been made for generations, has a heritage of craftsmanship and a culture of Italian know-how.

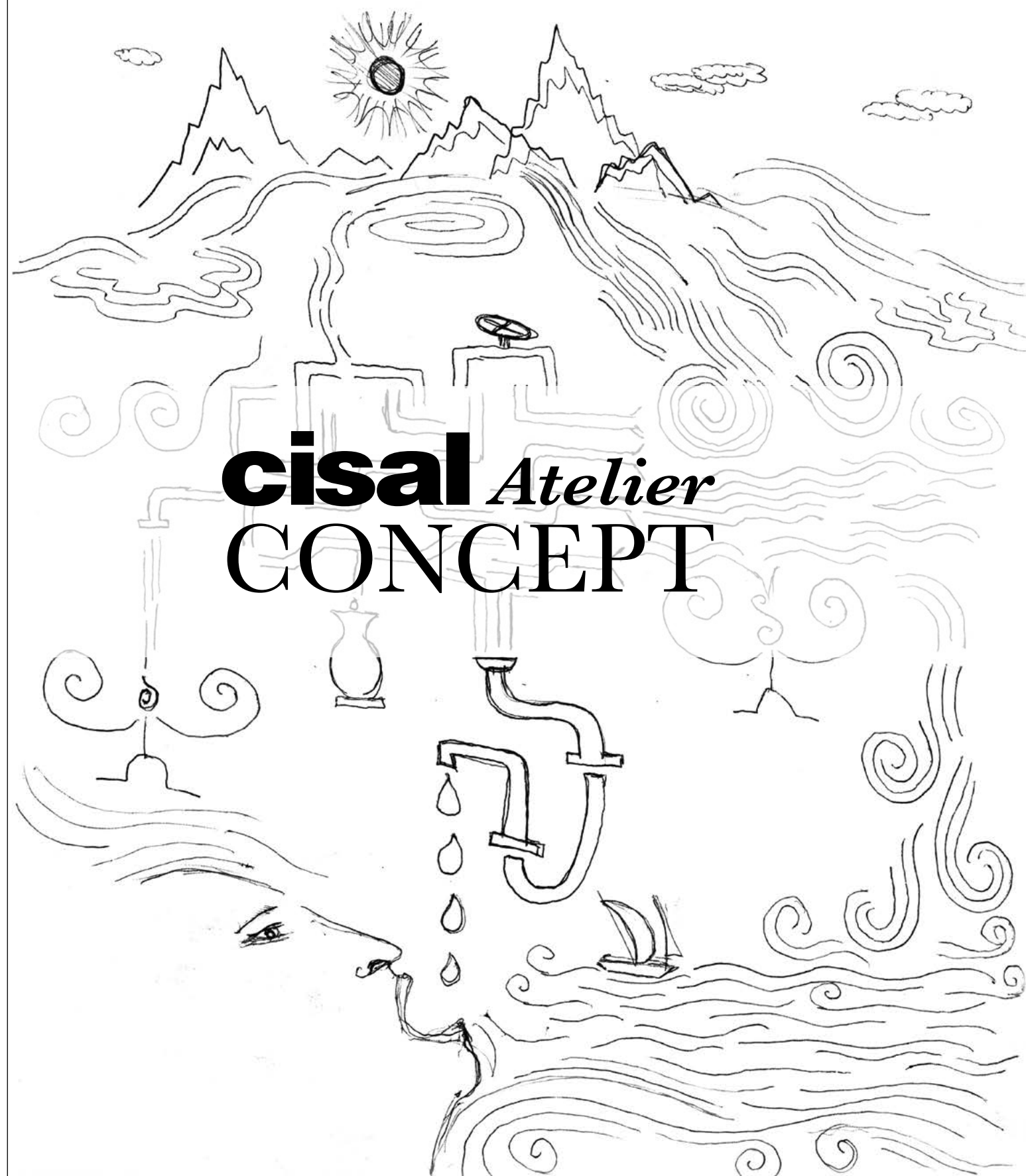

cisal *Atelier* CONCEPT

L'acqua è l'elemento essenziale per l'essere umano e il suo controllo è importante sin dall'antichità. Il rubinetto, dispensatore del liquido vitale del quale facciamo un utilizzo quotidiano, è un prodotto funzionale e necessario ma può anche rappresentare un accessorio sofisticato, prezioso e sempre più protagonista nell'ambiente bagno. Cisol storicamente ha da sempre caratterizzato la sua vasta gamma di collezioni con un atteggiamento di ricerca formale riferito al design. Più recentemente, con l'integrazione delle competenze della famiglia Huber, Cisol si è ulteriormente elevata ad ancora più alti livelli di qualità e prestigio, affermandosi come un importante interprete del settore bagno e cucina a livello internazionale.

Nel 2016 l'Architetto Fabio Rotella entra a far parte del team dell'azienda e in qualità di art director ha ideato "CISALAtelier", centro creativo che, attraverso la ricerca e la sperimentazione, lavorerà su progetti di prodotti sempre più protagonisti, grazie ad un autentico appeal.

"In questi anni di grandi cambiamenti, in un contesto internazionale sempre più sofisticato e in continua evoluzione, Cisol, nella sua nuova visione strategica, intende sviluppare ed elevare la propria immagine rendendola unica e riconoscibile, e aumentare la percezione dei suoi prodotti e delle sue innovazioni sullo scenario globale.

Nuovi materiali, nuove finiture, nuovi dettagli e nuove tecnologie per controllare e preservare l'acqua. Cisol si presenta come un'azienda Italiana di tradizione e all'avanguardia, proiettata verso il futuro e sempre più attenta alle attese di designers e utilizzatori e alla salvaguardia dell'elemento essenziale per il Pianeta: l'acqua."

Fabio Rotella

Water is the essential element for the human being - and controlling it has been important since ancient times. The tap, dispenser of this vital liquid of which we use daily, is a functional and necessary product, but it can also be a sophisticated, precious accessory as well that plays an increasingly important role in the bathroom environment. Since its origin, Cisol's wide range of collections have always been characterized by formal research related to design. Recently, with the integration of the expertise of the Huber family, Cisol has elevated its already high levels of quality and prestige even further, establishing itself internationally as a major interpreter of the bathroom and kitchen industry.

Architect Fabio Rotella joining the team in 2016: as the brand art director, he developed the "CISALAtelier" concept, a creative network which, through research and experimentation, will be used on projects of key products thanks to their authentic appeal.

"During these years of great change, in an international context that is becoming more sophisticated and is constantly evolving, Cisol, with its new strategic vision, aims to develop and enhance its image, making it unique and recognizable, and to globally increase the perception of its products and innovations.

New materials, new finishes, new details and new technologies to control and preserve water. Cisol is a cutting-edge, future-oriented Italian company that is rich in tradition and is increasingly aware of the expectations of designers and users, and the preservation of the essential element of our planet: water."

Fabio Rotella



WATER
creativity

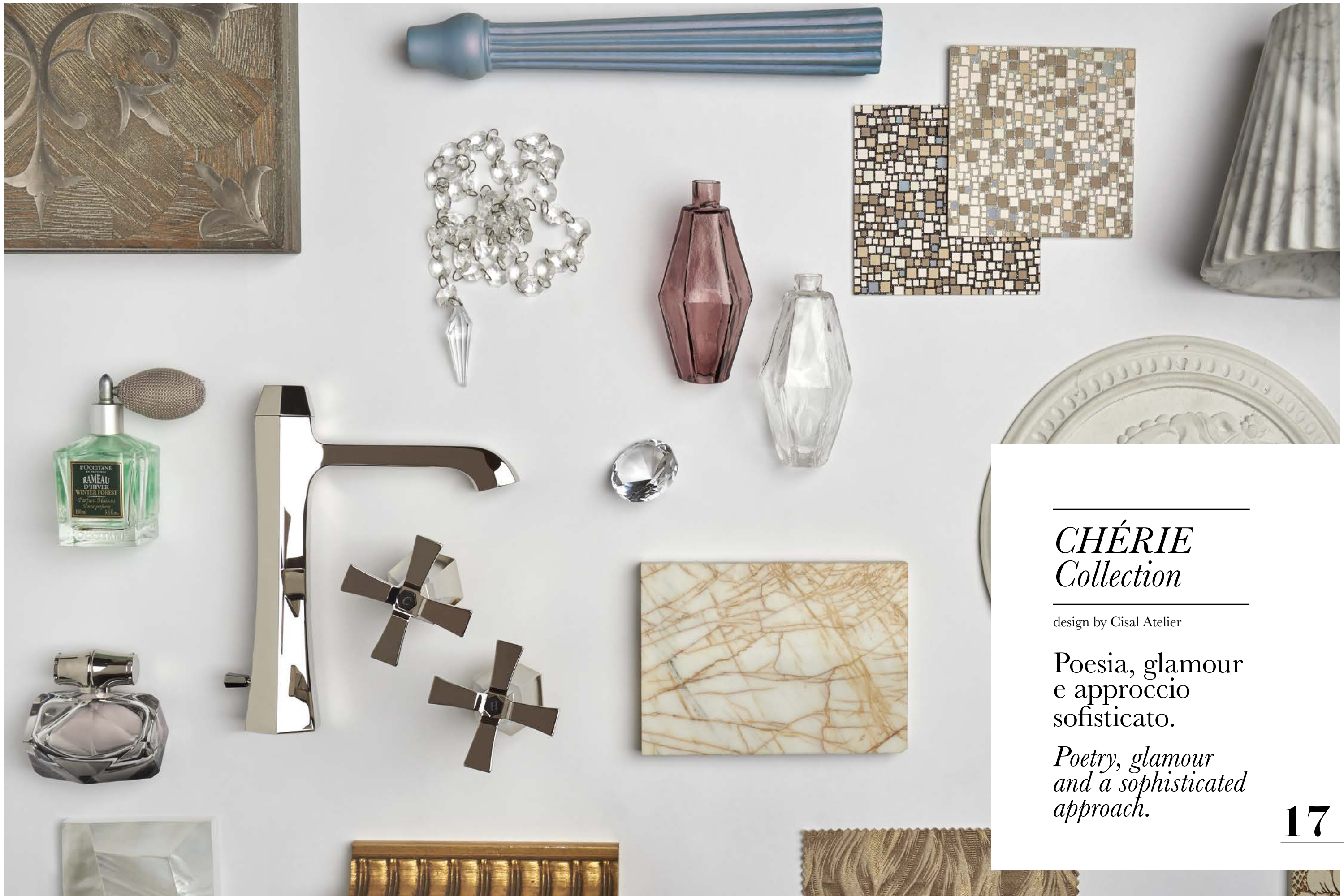

CHÉRIE *Collection*

design by Cital Atelier

Poesia, glamour
e approccio
s sofisticato.

*Poetry, glamour
and a sophisticated
approach.*

CHÉRIE



18

CX 106
Batteria Lavabo
Basin Set



19



20



CF 106
Batteria Lavabo
Basin Set

21

CHÉRIE



22

CH 354
Monocomando Lavabo
Basin Mixer



23

CHÉRIE



CH 51
Monocomando Lavabo
Basin Mixer



CH 551
Monocomando Lavabo
Basin Mixer

24



CH 55
Monocomando Bidet
Bidet Mixer

25

CHÉRIE



26

CF 1351
Batteria Lavabo
Basin Set



27



CX 1351
Batteria Lavabo
Basin Set





30

CX 420
Completo Miscelatore Vasca Free-Standing
Free-Standing Bath/S. Mixer Set



31



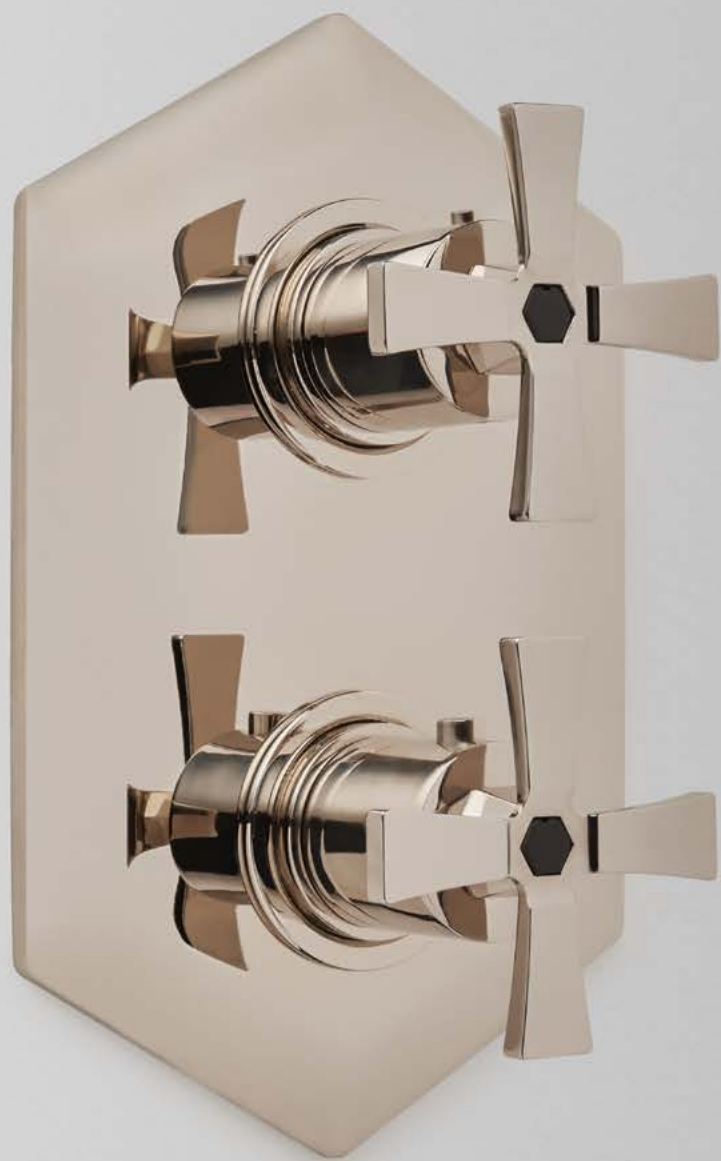

CX 930
Termostatico Doccia
Thermo Shower



CH 12
Completo Monocomando Vasca
Bath/S. Mixer Set



CX 26
Batteria Bordo Vasca
Deck Mounted Bath Set

CHÉRIE



36

DS 1327
Braccio e Soffione Doccia
Shower Arm & Head



37



38



CH 210
Monocomando 2 Uscite
2-Outlet Mixer



CE 303
Completo Doccia con Presa d'Acqua
Shower Set on Wall Elbow



CH 44
Monocomando Doccia
Shower Mixer

39



40

CE C8001
CombiDoccia Termostatico
Thermo CombiShower



41

CH 405
CombiDoccia Monocomando
CombiShower Mixer



CE 9042
Porta Rotolo
Roll Holder



CE 9010
Porta Salviette
Towel Rail



CE 9050
Porta Bicchiera
Tumbler Holder



CE 9060
Porta Sapone
Soap Holder



Prodotti e Accessori
Products and Accessories
Produits et Accessoires

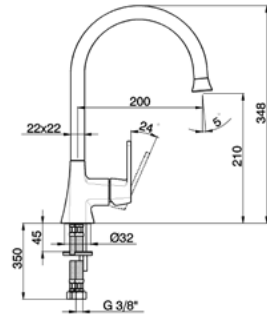

CH000534
Monocomando Lavabo Bocca Girevole
Swivel Spout Basin Mixer
Mitigeur Lavabo Bec Mobile

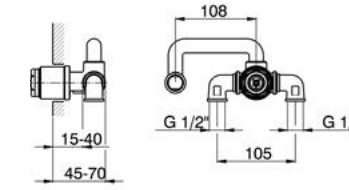

ZA006510
Parte Incasso Monocomando Lavabo
Basin Mixer Concealed Part
Partie Encastrée Mitigeur Lavabo

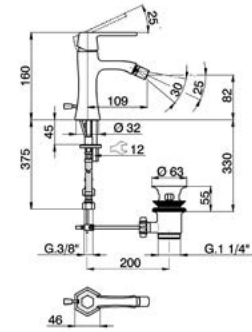

CH000554
Monocomando Bidet
Bidet Mixer
Mitigeur Bidet

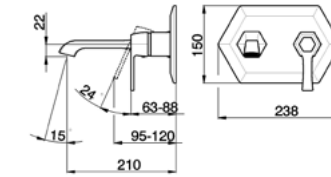

CH005510
Parte Esterna Monocomando Lavabo
Basin Mixer Exposed Part
Partie Apparente Mitigeur Lavabo

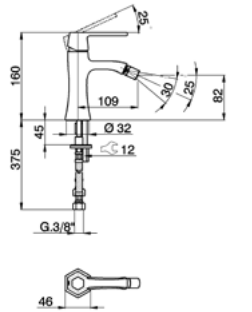

CH000564
Monocomando Bidet
Bidet Mixer
Mitigeur Bidet

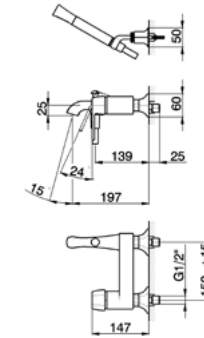

CH000124
Completo Monocomando Vasca
Bath/S. Mixer Set
Ensemble Mitigeur Bain/D.

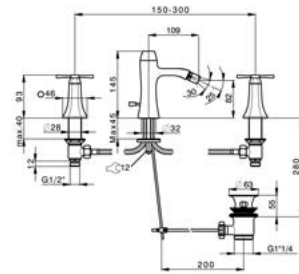

CX001220
Batteria Bidet
Bidet Set
Bidet 3 Trou

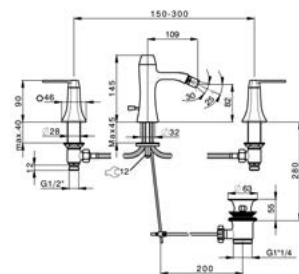

CF001220
Batteria Bidet
Bidet Set
Bidet 3 Trou

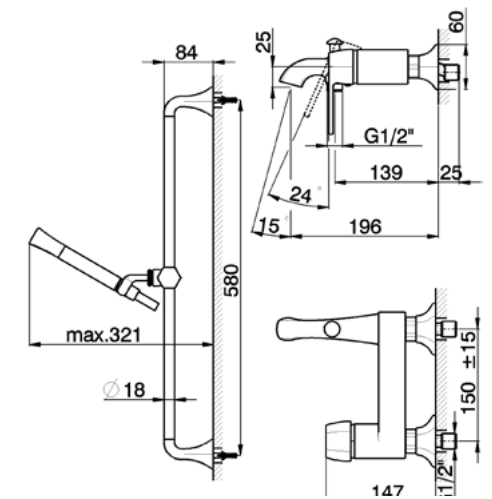

CH000064
Completo Monocomando Vasca
Bath/S. Mixer Set
Ensemble Mitigeur Bain/D.

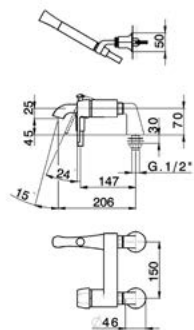

CH000094
Completo Monocomando Bordo Vasca
Deck Mounted Bath/S. Mixer Set
Ensemble Mitigeur Bain/D. sur Gorge

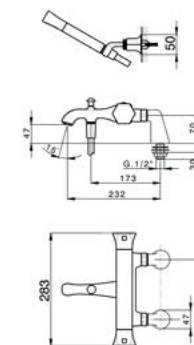

CED28010
Completo Termostatico Bordo Vasca
Deck Mounted Thermo Bath/S. Set
Ensemble Mitigeur Bain/D. sur Gorge

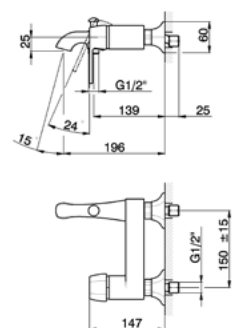

CH000134
Monocomando Vasca
Bath/S. Mixer
Mitigeur Bain/D.

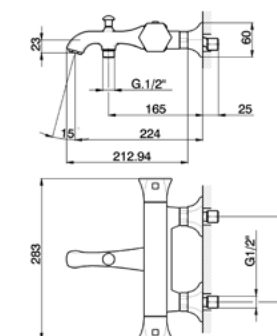

CET27010
Termostatico Vasca
Bath/S. Thermo
Thermo Bain/D.

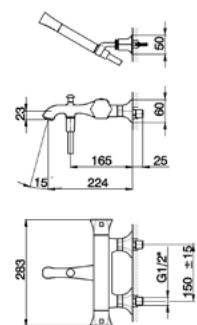

CED27010
Completo Termostatico Vasca
Thermo Bath/S. Set
Ensemble Thermo Bain/D.

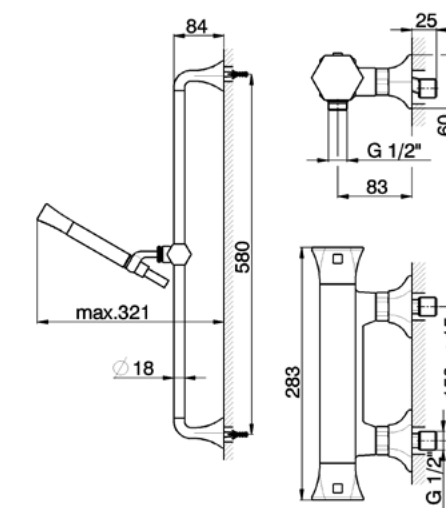
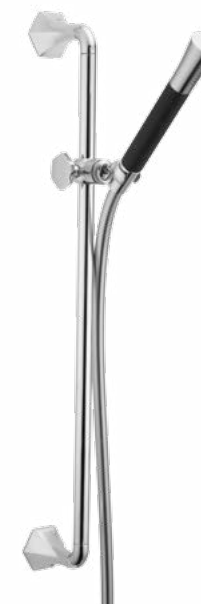

CES01010
Completo Termostatico Doccia
Thermo Shower Set
Ensemble Thermo Douche

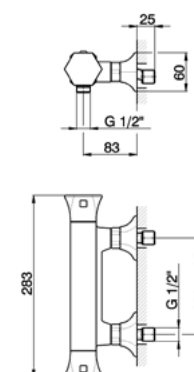

CET01010
Termostatico Doccia
Shower Thermo
Thermo Douche

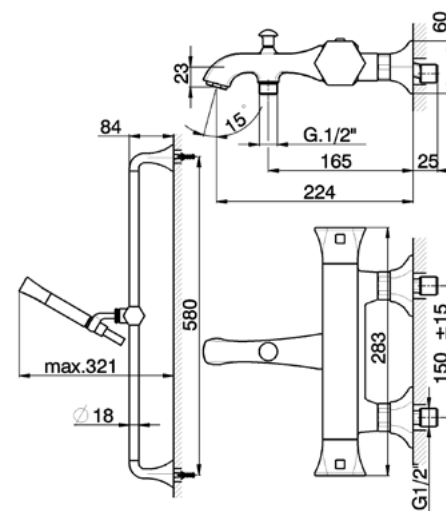

CES27010
Completo Termostatico Vasca
Thermo Bath/S. Set
Ensemble Thermo Bain/D.

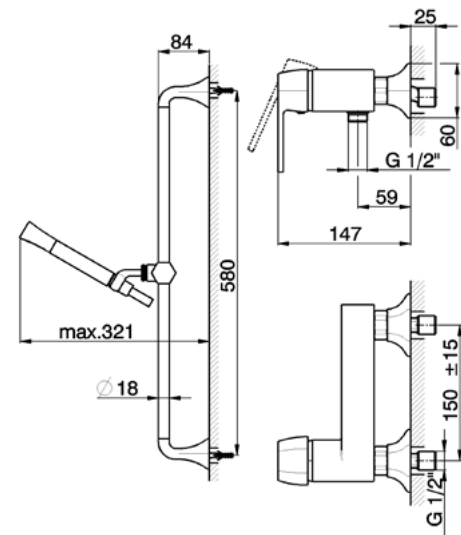

CH000464
Completo Monocomando Doccia
Shower Mixer Set
Ensemble Mitigeur Douche

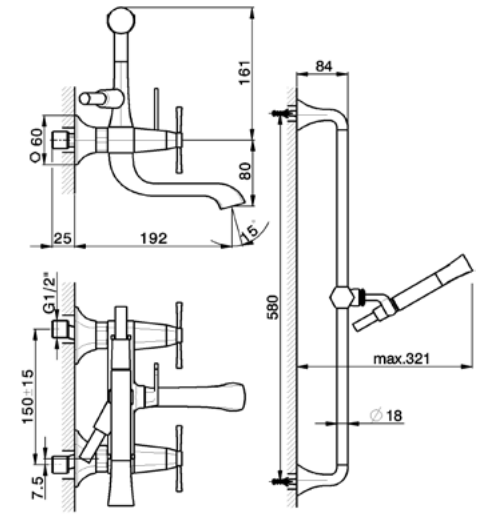

CX000060
Completo Miscelatore Vasca
Bath/S. Mixer Set
Ensemble Mélangeur Bain/D.

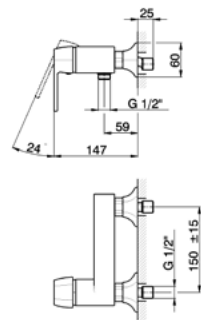

CH000444
Monocomando Doccia
Shower Mixer
Mitigeur Douche

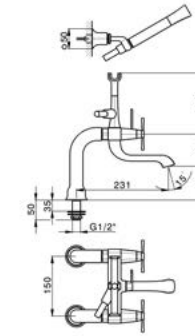

CX000090
Completo Miscelatore Bordo Vasca
Deck Mounted Bath/S. Mixer Set
Ensemble Mélangeur Bain/D. sur Gorge

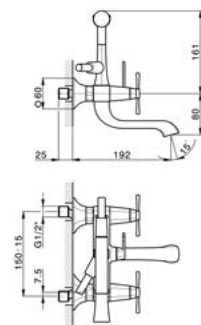

CX000100
Completo Miscelatore Vasca
Bath/S. Mixer Set
Ensemble Mélangeur Bain/D.

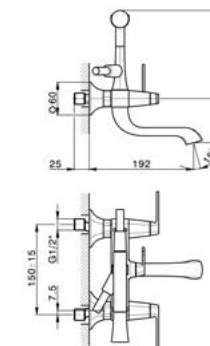

CF000100
Completo Miscelatore Vasca
Bath/S. Mixer Set
Ensemble Mélangeur Bain/D.

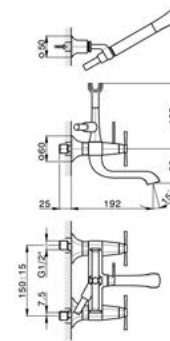

CX000120
Completo Miscelatore Vasca
Bath/S. Mixer Set
Ensemble Mélangeur Bain/D.

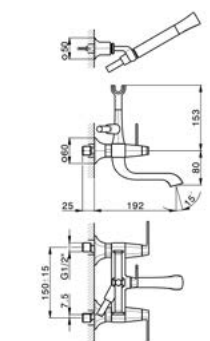

CF000120
Completo Miscelatore Vasca
Bath/S. Mixer Set
Ensemble Mélangeur Bain/D.

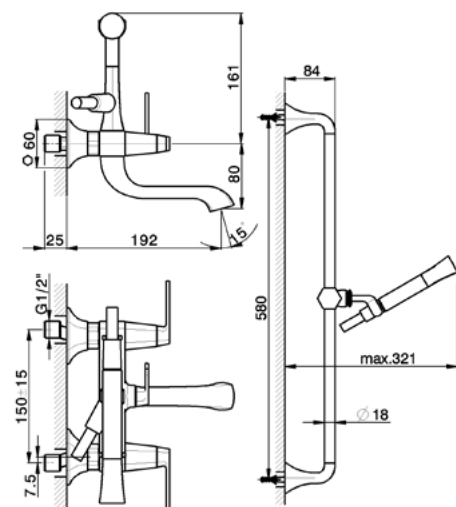

CF000060
Completo Miscelatore Vasca
Bath/S. Mixer Set
Ensemble Mélangeur Bain/D.

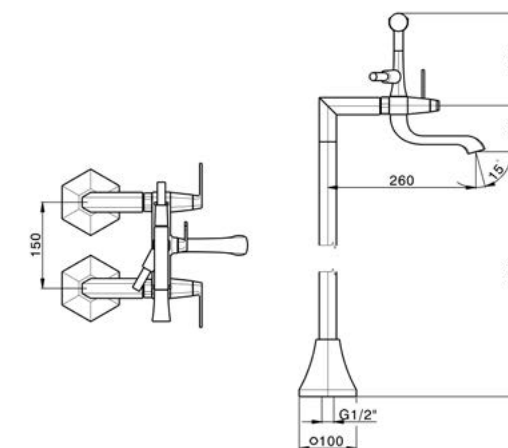

CF004200
Completo Miscelatore Vasca Free-Standing
Free-Standing Bath/S. Mixer Set
Ensemble Mélangeur Bain/D. Free-Standing

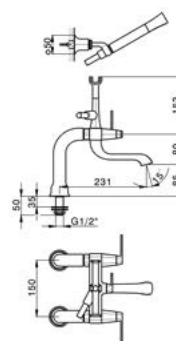

CF000090
Completo Miscelatore Bordo Vasca
Deck Mounted Bat/S. Mixer Set
Ensemble Mélangeur Bain/D. sur Gorge

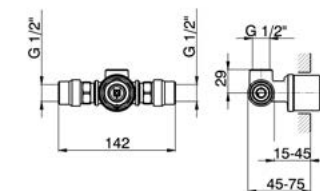

ZA004310
Parte Incasso Monocomando Doccia
Shower Mixer Concealed Part
Partie Encastrée Mitigeur Douche

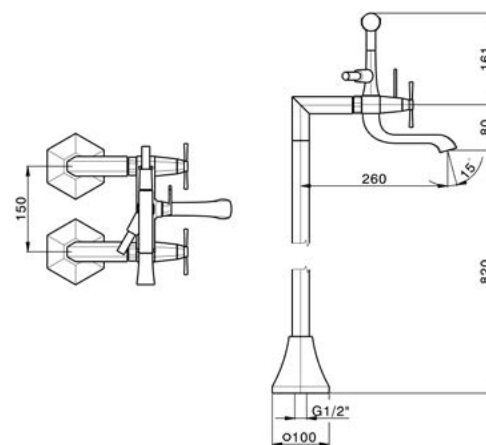

CX004200
Completo Miscelatore Vasca Free-Standing
Free-Standing Bath/S. Mixer Set
Ensemble Mélangeur Bain/D. Free-Standing

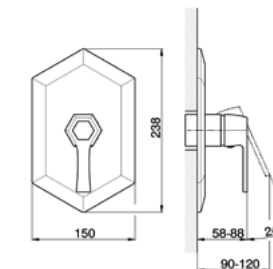

CH003000
Parte Esterna Monocomando Doccia
Shower Mixer Exposed Part
Partie Décor Mitigeur Douche

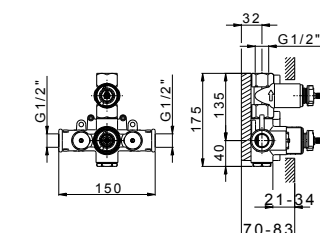

ZA009300
Parte Incasso Termostatico Doccia
Thermo Shower Concealed Part
Partie Encastrée Thermo Douche

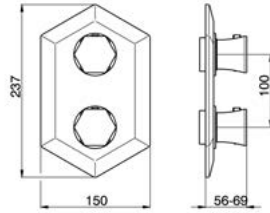

CE009300
 Parte Esterna Termostatico Doccia
 Thermo Shower Exposed Part
 Partie Décor Thermo Douche

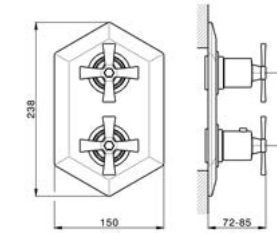

CX019100
 Parte Esterna Termostatico 2 Uscite
 2-Outlet Thermo Exposed Part
 Partie Décor Thermo 2 Sorties

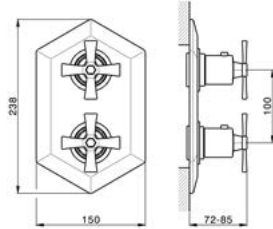

CX009300
 Parte Esterna Termostatico Doccia
 Thermo Shower Exposed Part
 Partie Décor Thermo Douche

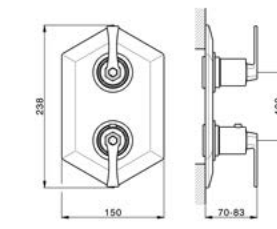

CF019100
 Parte Esterna Termostatico 2 Uscite
 2-Outlet Thermo Exposed Part
 Partie Décor Thermo 2 Sorties

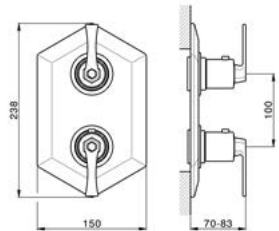

CF009300
 Parte Esterna Termostatico Doccia
 Thermo Shower Exposed Part
 Partie Décor Thermo Douche

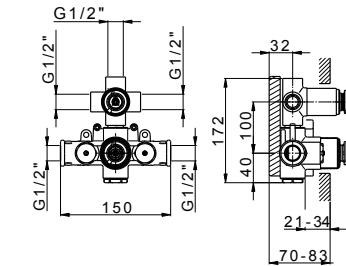

ZA019200
 Parte Incasso Termostatico 3 Uscite
 3-Outlet Thermo Concealed Part
 Partie Encastrée Thermo 3 Sorties

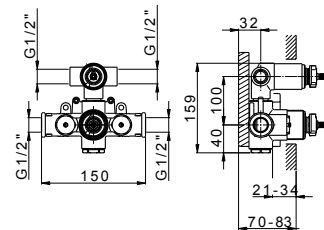

ZA019100
 Parte Incasso Termostatico 2 Uscite
 2-Outlet Thermo Concealed Part
 Partie Encastrée Thermo 2 Sorties

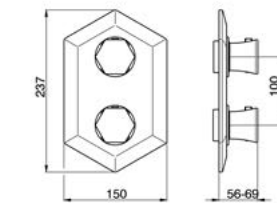

CE019200
 Parte Esterna Termostatico 3 Uscite
 3-Outlet Thermo Exposed Part
 Partie Décor Thermo 3 Sorties

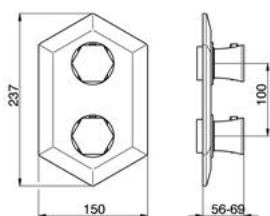

CE019100
 Parte Esterna Termostatico 2 Uscite
 2-Outlet Thermo Exposed Part
 Partie Décor Thermo 2 Sorties

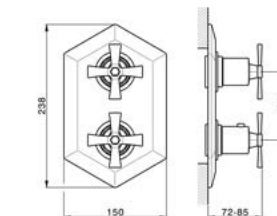

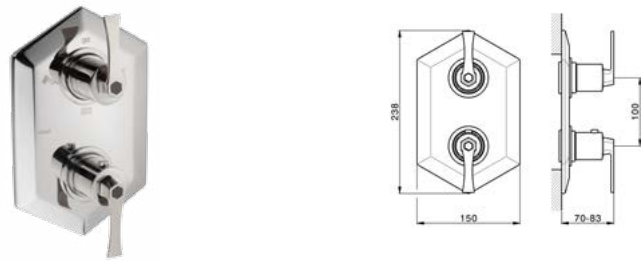

CX019200
 Parte Esterna Termostatico 3 Uscite
 3-Outlet Thermo Exposed Part
 Partie Décor Thermo 3 Sorties

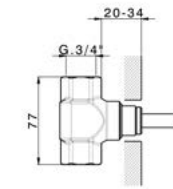

CF019200
 Parte Esterna Termostatico 3 Uscite
 3-Outlet Thermo Exposed Part
 Partie Décor Thermo 3 Sorties



ZA003310 
 Parte Incasso Rubinetto 3/4"
 3/4" Stopvalve Concealed Part
 Partie Encastrée Robinet 3/4"

ZA003311 

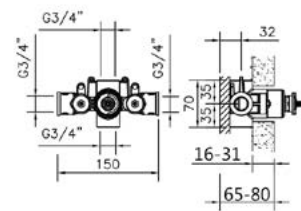

ZA007220
 Parte Incasso Termostatico 3/4"
 3/4" Thermo Concealed Part
 Partie Encastrée Thermo 3/4"

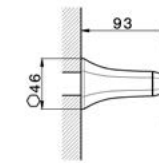

CX003310
 Parte Esterna Rubinetto
 Stopvalve Exposed Part
 Partie Décor Robinet

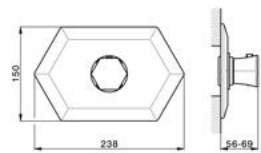

CE007200
 Parte Esterna Termostatico 3/4"
 3/4" Thermo Exposed Part
 Partie Décor Thermo 3/4"

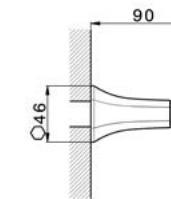

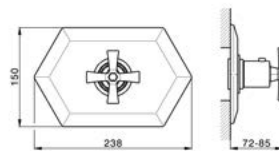

CF003310
 Parte Esterna Rubinetto
 Stopvalve Exposed Part
 Partie Décor Robinet

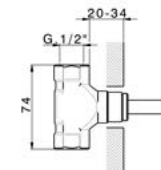

CX007200
 Parte Esterna Termostatico 3/4"
 3/4" Thermo Exposed Part
 Partie Décor Thermo 3/4"



ZA003320 
 Parte Incasso Rubinetto 1/2"
 1/2" Stopvalve Concealed Part
 Partie Encastrée Robinet 1/2"

ZA003321 

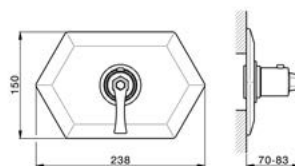

CF007200
 Parte Esterna Termostatico 3/4"
 3/4" Thermo Exposed Part
 Partie Décor Thermo 3/4"

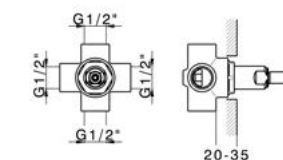

ZA002000
 Parte Incasso Deviatore 2 Uscite
 2-Outlet Diverter Concealed Part
 Partie Encastrée Inverseur 2 Sorties

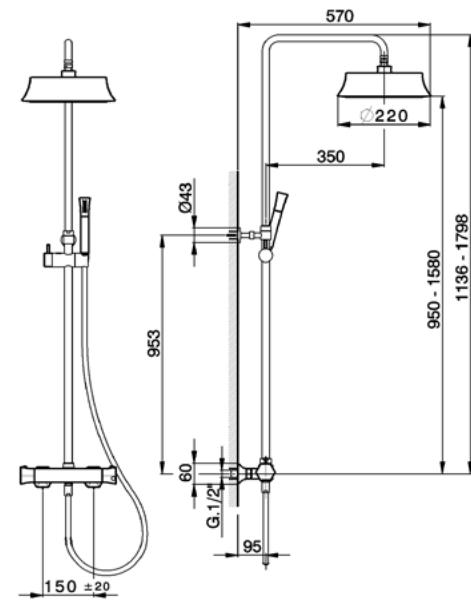

CEC82010
CombiDoccia Termostatico
Thermo CombiShower
CombiDouche Thermo

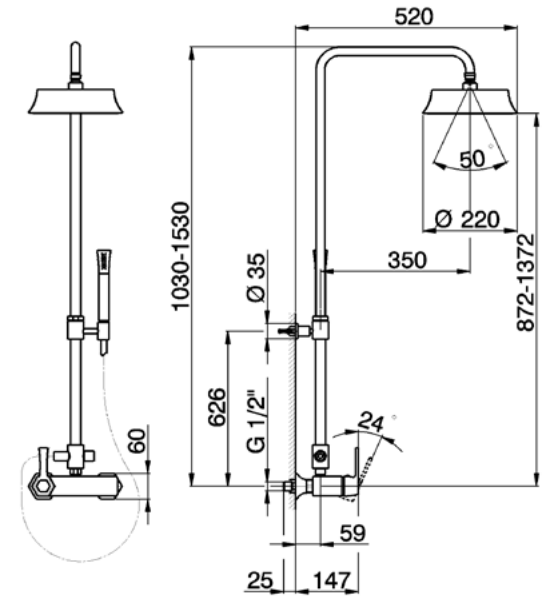

CH004024
CombiDoccia Monocomando
CombiShower Mixer
CombiDouche Mitigeur

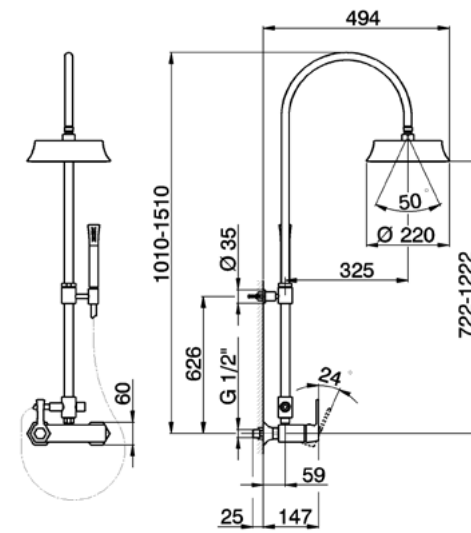

CH004054
CombiDoccia Monocomando
CombiShower Mixer
CombiDouche Mitigeur

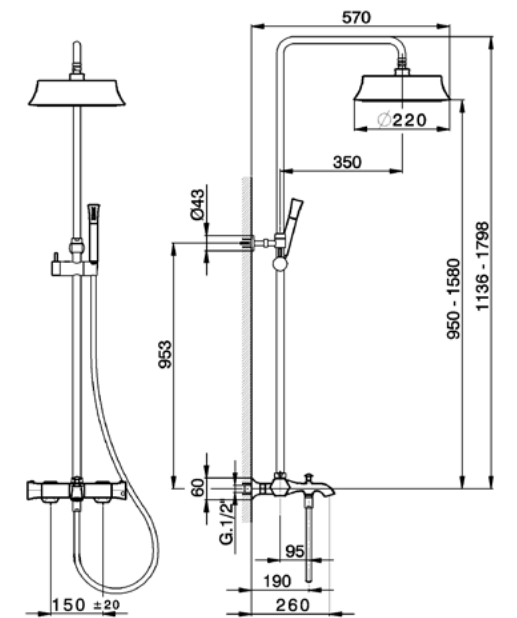

CEC83010
CombiVasca Termostatico
Thermo CombiBath
CombiBain Thermo

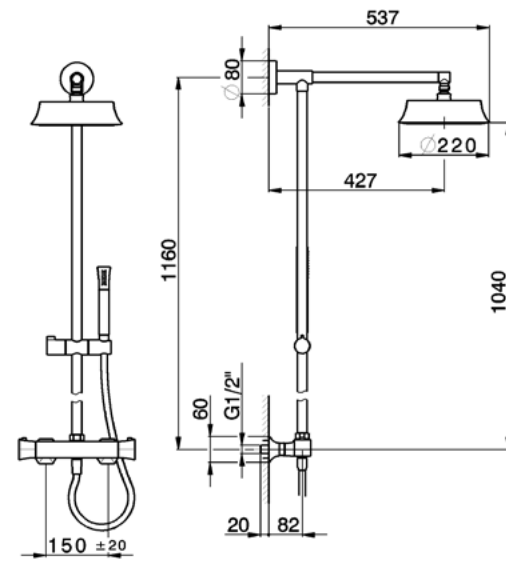

CEC78010
CombiDoccia Termostatico
Thermo CombiShower
CombiDouche Thermo

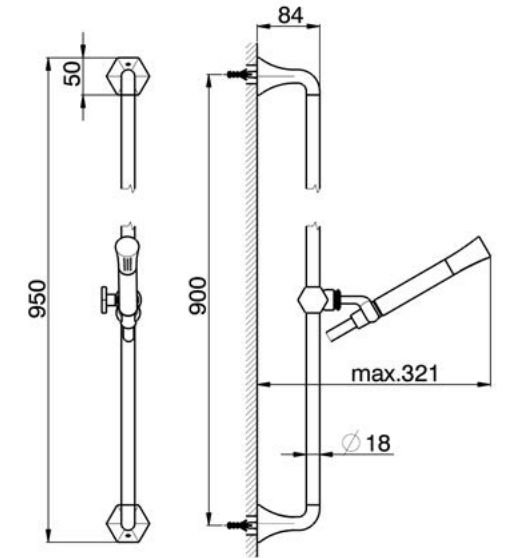

CE003111
Completo Doccia Saliscendi 900mm
900mm Slide Rail Shower Set
Ensemble Barre de Douche 900mm

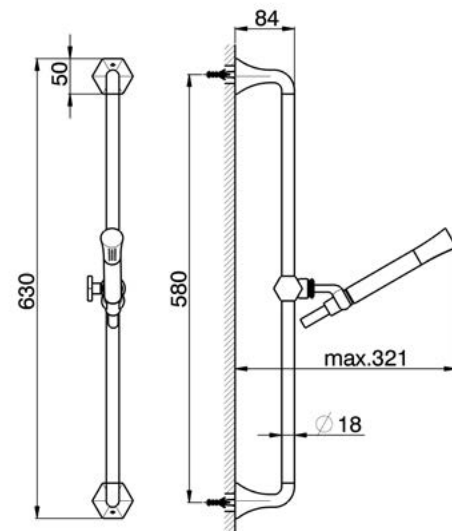

CE003110
Completo Doccia Saliscendi 580mm
580mm Slide Rail Shower Set
Ensemble Barre de Douche 580mm

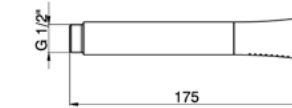

DS014200
Doccetta
Hand Shower
Douchette à Main

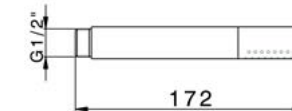

DS014090
Doccetta
Hand Shower
Douchette à Main

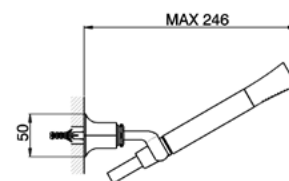

DS018090
Completo Doccia
Shower Set
Ensemble de Douche

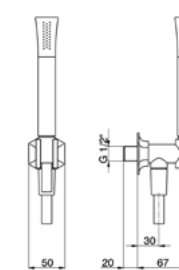

CE003030
Completo Doccia con Presa d'Acqua
Shower Set on Wall Elbow
Ensemble de Douche sur Coude Mural



ZA009040
Flessibile Doccia SILVERFLEX
SILVERFLEX Shower Hose
Flexible de Douche SILVERFLEX

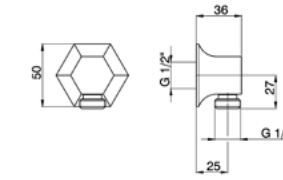

CE017000
Pres a d'Acqua a Parete
Wall Elbow
Coude Mural



DS013270
Braccio e Soffione Doccia
Shower Arm & Head
Bras et Tête de Douche

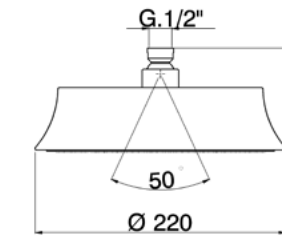

DS016200
Soffione Doccia
Shower Head
Douche de Tête

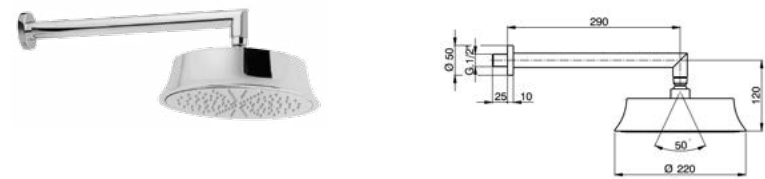

DS013590
Braccio e Soffione Doccia
Shower Arm & Head
Bras et Tête de Douche

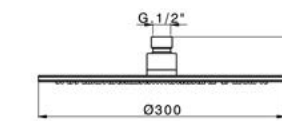

DS016330
Soffione Doccia
Shower Head
Douche de Tête



DS013600
Braccio e Soffione Doccia
Shower Arm & Head
Bras et Tête de Douche

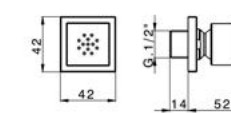

DS015080
Soffione Laterale
Body Jet
Buse Murale



DS013280
Braccio e Soffione Doccia
Shower Arm & Head
Bras et Tête de Douche

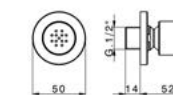

DS015090
Soffione Laterale
Body Jet
Buse Murale

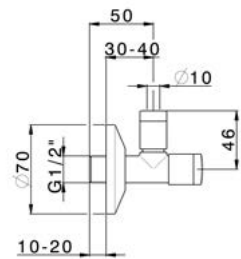

ZA002900
 Rubinetto Filtro di Alimentazione
 Angle Valve
 Robinet à equerre

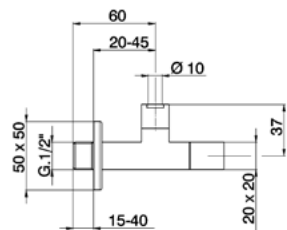

ZA002910
 Rubinetto Filtro di Alimentazione
 Angle Valve
 Robinet à equerre

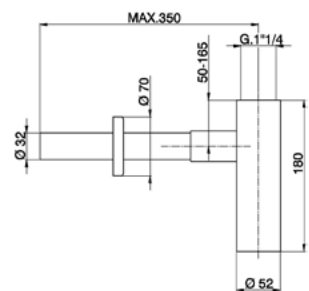

ZA004070
 Sifone
 Siphon
 Siphon

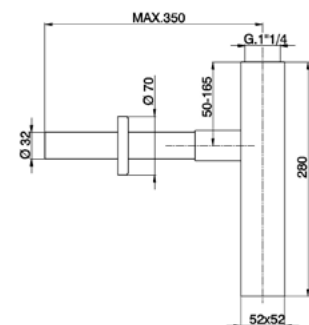

ZA004080
 Sifone
 Siphon
 Siphon



ZA001620
 Scarico Click-Clack
 Click-Clack Waste
 Vidage Click-Clack

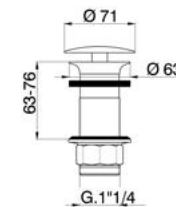

ZA001611
 Scarico Sempre Aperto
 Open Flow Waste
 Vidage Ouvert

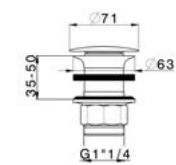

ZA001610
 Scarico Sempre Aperto
 Open Flow Waste
 Vidage Ouvert

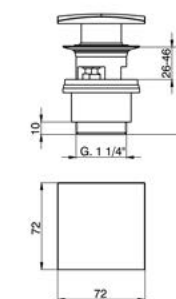

ZA001622
 Scarico Click-Clack
 Click-Clack Waste
 Vidage Click-Clack

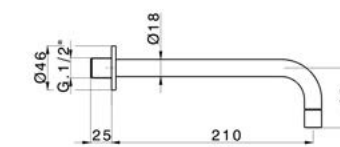

ZA002250
 Bocca di Erogazione
 Filler Spout
 Bec Verseur

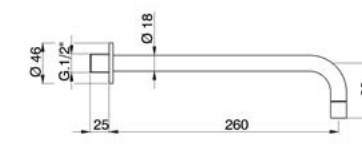

ZA002251
 Bocca di Erogazione
 Filler Spout
 Bec Verseur

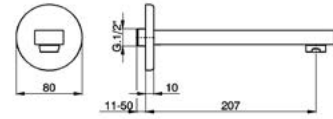
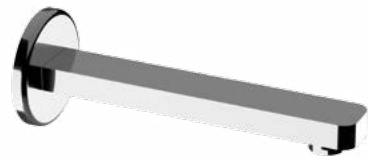

RR000240
Bocca di Erogazione
Filler Spout
Bec Verseur

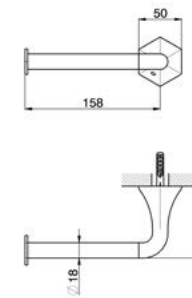

CE090400
Porta Rotolo
Roll Holder
Porte-Papier

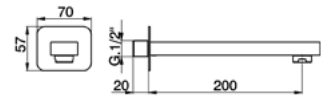
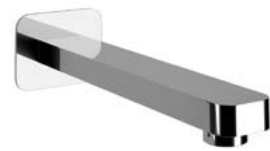

CU000240
Bocca di Erogazione
Filler Spout
Bec Verseur

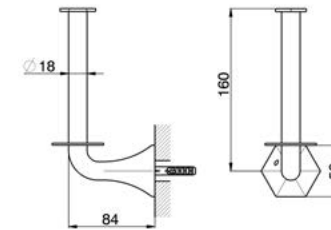

CE090410
Porta Rotolo
Roll Holder
Porte-Papier

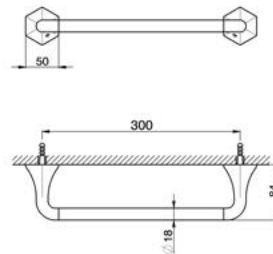

CE090100
Porta Salviette
Towel Rail
Porte-Serviette

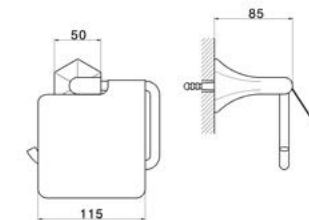

CE090420
Porta Rotolo
Roll Holder
Porte-Papier

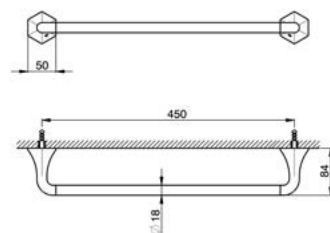

CE090101
Porta Salviette
Towel Rail
Porte-Serviette

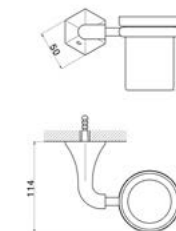

CE090500
Porta Bicchiera
Tumbler Holder
Porte-Verre

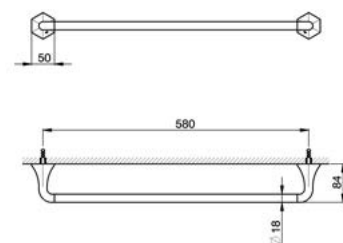

CE090102
Porta Salviette
Towel Rail
Porte-Serviette

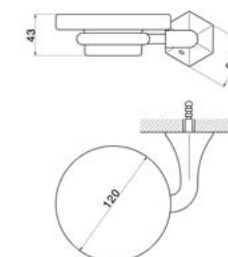

CE090600
Porta Sapone
Soap Holder
Porte-Savon

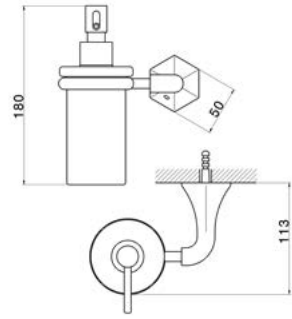

CE090620
Dispenser Sapone
Soap Dispenser
Diffuseur de Savon

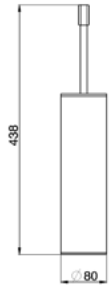

CE090650
Porta Scopino Free-Standing
Free-Standing Brush Holder
Porte-Brosse

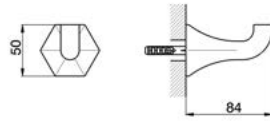

CE090710
Appendino
Hook
Porte-Peignoir

METALLI CLASSICI | CLASSIC METALS



Chrome
2I



Polished Nickel
2B



Brushed Nickel
2F

METALLI SPECIALI PVD | PVD SPECIAL METALS



Black Titanium
2Q



Rose Gold
2P



Silver Nickel
2T

METALLI SPECIALI | SPECIAL METALS



24K Gold
24



Antique Gold
2G



Satin Gold
2R

cisal

cisal



CISAL
28010 Alzo di Pella (NO) - Italia - Via Pietro Durio 160 - Tel. +39 0322 918111 - Fax +39 0322 969518
cisal@cisal.it - www.cisal.it